



LAM-É
ST-PIERRE



FLOOR TENSION BRACED JIB CRANE

JIB CRANE APPLICATION EVALUATION

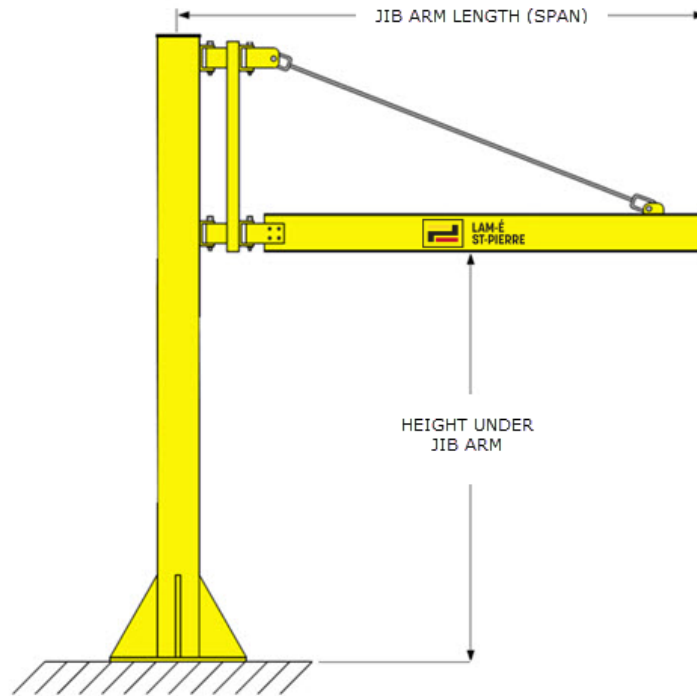

REQUIRED SPECIFICATIONS	
Capacity Required :	
Height under jib arm:	
Span:	
CONTACT INFORMATIONS	
Name and Company Name:	
Adresse :	
Phone :	
Email:	



LAM-É
ST-PIERRE

www.lamestierre.com

Montréal		T 514 354-4219	/	1 800 361-4019
Québec		T 418 652-9759	/	1 800 652-9759
Saguenay		T 418 696-9759	/	1 866 696 9759